



**REQUEST FOR TENDER (RFT)**

**For the provision of Steel Landfill Cover Plates**

<b>Tender Information</b>	<b>No. RFT ENV 23-001</b>
<b>Issue Date:</b>	May 12, 2023
<b>Site Visit:</b>	None required
<b>Closing Date:</b>	June 2, 2023 at noon
<b>Opening Date:</b>	June 2, 2023 at 1:00 PM
<b>Address:</b>	Township of Minden Hills 7 Milne Street, PO Box 359 Minden, ON K0M 2K0
<b>Attention:</b>	Mike Timmins, Director of Public Works
<b>Last Day for Inquiries:</b>	May 30, 2023 at noon
<b>Bidder Information</b>	
<b>Name/Company:</b>	_____
<b>Contact Name:</b>	_____

**LATE SUBMISSIONS WILL NOT BE ACCEPTED.**

**THE LOWEST OR ANY SUBMISSIONS MAY NOT NECESSARILY BE ACCEPTED.**

# 1 Table of Contents

<b>2</b>	<b>General Conditions</b> .....	<b>4</b>
2.1	Definitions .....	4
2.2	Handling .....	4
2.3	Submission Mandatory Requirements .....	4
2.4	Manufacturer’s Specifications.....	5
2.5	Equivalent .....	5
2.6	Harmonized Sales Tax (HST).....	6
2.7	Multiple Submissions.....	6
2.8	Closing .....	6
2.9	Opening.....	6
2.10	Withdrawal or Alteration(s).....	6
2.11	Examination of Documents .....	7
2.12	Omissions, Discrepancies and Interpretations.....	7
2.13	Inquiries .....	7
2.14	Addenda .....	8
2.15	Acceptance or Rejection of Submission(s).....	8
2.16	Award Procedures.....	9
2.17	Ability and Experience of Respondent .....	9
2.18	Variation of Quantities .....	10
2.19	Limited Liabilities .....	10
2.20	Respondent Expense .....	10
2.21	Contract Negotiations .....	10
2.22	Conflict of Interest.....	10
2.23	Freedom of Information .....	11
2.24	Package Submissions Information Release to Other Respondents .....	11
2.25	Access to Information.....	11
2.26	Warranty.....	12
<b>3</b>	<b>Contractual Requirements</b> .....	<b>13</b>
3.1	Occupational Health and Safety.....	13
3.2	Workplace Safety Insurance Board (WSIB).....	14
3.3	Indemnification .....	15
3.4	Force Majeure .....	15
3.5	Insurance Requirements.....	15
3.6	Protection of Work and Property .....	17
3.7	Regulation Compliance and Legislation.....	17
3.8	Workplace Violence and Harassment.....	17
3.9	Code of Conduct.....	17
3.10	Smoke Free Workplace .....	17
3.11	Accessibility.....	18
3.12	Contract.....	18
3.12.1	Assignment of Contract .....	19
3.12.2	Sub-Contracting.....	19
3.12.3	Contract Amendments and Revisions .....	19
3.12.4	Cancellation of Contract .....	19
3.13	Conflict of Interest.....	19
3.14	Bankruptcy.....	20
3.15	Governing Laws.....	20
3.16	Delivery and Execution of Work .....	20

3.17	Pre-Start Meeting.....	20
3.18	Terms of Payment .....	20
3.19	Settlement of Disputes.....	21
3.20	Guarantee of Performance.....	21
3.21	Successful Respondent Performance Evaluation .....	22
3.22	Taxes .....	22
3.23	Notices .....	22
<b>4</b>	<b>RFT Specifications .....</b>	<b>23</b>
4.1	Overview .....	23
4.2	Specifications .....	23
4.3	Respondent Experience.....	23
4.4	Respondent Responsibilities .....	24
4.5	Township Responsibilities .....	24
4.6	Pricing Requirements .....	24
4.7	General Instructions.....	24
4.8	Other Instructions .....	24
4.9	Cooperative Purchasing .....	25
<b>5</b>	<b>Evaluation Process.....</b>	<b>26</b>
5.1	Evaluation Stages.....	26
5.2	Total Evaluation Points Available .....	27
<b>6</b>	<b>Appendices.....</b>	<b>28</b>
6.1	Appendix A – Submission Requirements .....	28
6.2	Appendix B - Experience, References & Contingencies .....	29
6.3	Appendix C - Suppliers & Subcontractors .....	30
6.4	Appendix D - Respondent Information .....	31
6.5	Appendix E – Declaration Form .....	32
6.6	Appendix F - Price & Delivery Schedule .....	33
6.7	Appendix G - Guarantee of Performance/Cancellation of Contract or Provision of Goods and/or Services.....	34
6.8	Appendix H - Agreement Acknowledgement .....	35
6.9	Appendix I – Sample Photos .....	36
6.10	Appendix J – Excavator Bucket Dimensions .....	37
6.11	Appendix K – Delivery Notice .....	38

## 2 General Conditions

---

### 2.1 Definitions

**“Corporation/Owner/Township”** Refers to the Township of Minden Hills.

**“Form of RFT”** Refers to this document and its processes.

**"Facilities"** means any property used by and/or under the control of the Township and includes any infrastructure, electronic transmission and storage devices used by the Township.

**“Respondent”** Refers to any eligible entity providing a response to this RFP, RFQ, RFT, etc.

**“Site or Sites”** Refers to the Township of Minden Hills Waste Disposal Site(s) and Recycling Centre(s) and all equipment, buildings and improvements within the property.

**“Successful Respondent”** Refers, in the event of an award, to the selected Respondent.

**“Work or the provision of Goods and/or Services”** Refers to the scope of work, and specifications outline in this RFT.

### 2.2 Handling

The handling of this document and any other document(s) related to this RFT will be in accordance with the Township of Minden Hills Policy No. 17 governing the procurements of goods and services, and this document.

### 2.3 Submission Mandatory Requirements

All submissions must be completed in hard copy and must include all Appendices attached to this document. All entries shall be clear, legible, in a non-erasable medium and signed (where applicable). Entries must be made for unit price, lump sum, extensions and totals as appropriate. All items shall be responded to according to instructions contained within this document(s).

- Appendix A – Submission Requirements
- Appendix B – Experience, References & Contingencies
- Appendix C – Suppliers & Subcontractors
- Appendix D – Respondent Information
- Appendix E – Declaration Form
- Appendix F – Price & Delivery Schedule
- Appendix G – Guarantee of Performance/Cancellation of Contract
- Appendix H – Agreement Acknowledgement
- Appendix I – Sample Photos
- Appendix J – Excavator Bucket Specifications
- Appendix K - Delivery Notice

Submissions received after the official closing time will not be considered during the selection process.

### **In Person Drop-off Submissions:**

Hard copy (in person) submissions are to be hand delivered to the Township before the submission deadline noted in the RFT document.

Respondents may contact the Township at [tenders@mindenhills.ca](mailto:tenders@mindenhills.ca) to schedule an appointment for person-to-person drop-off.

**Submissions placed in the Township Drop Box will not be accepted.**

Respondents will receive receipt of submission at the time of drop-off.

For questions or concerns regarding this matter, please contact the Township directly as outlined in Section 2.13 – Inquiries of the RFT document.

The Respondent warrants that all contents of their submission are complete and accurate.

It is the responsibility of the Respondent to ensure they comply with this procedure. The Township is not responsible for submissions which are not properly marked and/or delivered to any other location, other than that specified herein.

Late proposals will not be considered. \*Local time is according to the time clock located in the Township offices, which will be deemed to be taken as conclusive. (HR.:MIN.:SEC.) Late proposals will be returned unopened to the respondent. Responses that are not submitted in the requested format or are incomplete, conditional, illegible or obscure, or that contain additions not called for, reservations, erasures, and alterations incorrectly submitted, restricted by a statement or irregularities of any kind may be rejected as per the Township's Procurement Policy, unless otherwise provided herein.

Person(s) signing the prescribed forms must be authorized to sign on behalf of the Respondent represented, and to bind the Respondent to statements made in response to this RFT. If a joint response is submitted, it must be signed and addressed on behalf of each of the Respondents.

Submissions received after the official closing time will not be considered during the selection process.

## **2.4 Manufacturer's Specifications**

Respondents shall include with their submission the full manufacturers' specifications and literature (where applicable), which fully describe the item(s) being offered, including any optional equipment.

## **2.5 Equivalent**

Where applicable, the Township has specified certain product(s) and/or brand names throughout this document for a number of the components utilized in the goods and/or services. In some instances, the Township would be willing to consider an equivalent for

the specified item. "Equivalent" would mean an equivalent product, design, manufacturer, etc. that, in the opinion of the Township is an "acceptable" alternative. The determination of the item to be an "acceptable" equivalent will be at the sole discretion of the Township.

Where a product, design, manufacturer, etc. has been stipulated and, there is no alternative option, Respondents must submit based on the specified item and, without substitution.

## **2.6 Harmonized Sales Tax (HST)**

HST is applicable to the item(s) listed, however, is not to be included in the Tendered unit cost. Submit all prices "HST Extra".

## **2.7 Multiple Submissions**

Respondents wishing to provide more than one (1) submission for consideration must complete a separate response for each and clearly identify each submission as a separate offer.

## **2.8 Closing**

Submissions must be received by the Township of Minden Hills on/before **June 2, 2023 at 12:00 noon Local Time.**

In the event that an emergency, staff labour disruption or inclement weather forces the suspension of services of the Township, by closing of the office, the submission shall become due on the next business day at 11:00 am, local time, after the original closing date and time.

A response received prior to suspension of services (closing of the office) may be withdrawn and replaced by a new submission and due before the amended closing date and time. Call 705-286-1260 ext. 513 for information in the event of a suspension of service for any additional information.

## **2.9 Opening**

A public opening will be held in the Township Administration Office at 7 Milne Street, Minden, ON, on June 2, 2023 at 1:00 PM. The results of the opening will be recorded and posted within two (2) business days on the Township website.

## **2.10 Withdrawal or Alteration(s)**

A Respondent may submit more than one response at any time up to the specified time and date of the closing outlined in Section 2.8. The last submission received shall supersede and invalidate all submissions previously submitted by that Respondent.

A Respondent may withdraw or alter the Submission at any time up to the specified time and date of the closing outlined in Section 2.8 by submitting a letter (on Respondent letterhead where available) bearing the Respondent's signature to the contact identified in Section 2.13 who will mark thereon the time and date of receipt and will place the letter in the Tender file. The Respondent's name and contract number shall be shown on the envelope containing such letter. Emails, facsimiles (faxes), or telephone calls will not be

accepted.

Submissions withdrawn under this procedure cannot be reinstated. Adjustments or corrections to a response already submitted will not be allowed.

## **2.11 Examination of Documents**

Each Respondent must satisfy himself/herself by a personal study of the RFT documents, by calculations, and by personal inspection of the site, respecting the conditions existing or likely to exist in connection with the proposed work or goods and/or services. There will be no consideration of any claim, after submission, that there is a misunderstanding with respect to the conditions imposed by this RFT.

Prices bid must include all incidental costs and the Respondent must be satisfied as to the full requirements of the RFT. No extra work will be entertained without prior Township approval. Should the Respondent require more information or clarification on any point, it must be obtained via the contact identified in Section 2.13 prior to submitting a response to this RFT.

## **2.12 Omissions, Discrepancies and Interpretations**

It is understood, acknowledged and agreed that while this document and related documents include(s) specific requirements and specifications, and while the Township has used considerable efforts to ensure an accurate representation of information, the information is not guaranteed by the Township to be accurate, nor necessarily comprehensive or exhaustive.

Nothing in this document or related documents is intended to relieve the Respondent from forming their own opinions and conclusions with respect to the matters addressed in this RFT.

The submission of a response shall be deemed proof that the Respondent is satisfied as to all the provisions of the submission, all conditions which may be encountered, all work or goods and/or services required, or any other matter which may enter into the carrying out of the work or supply of goods and/or services referred to in this RFT. No claims will be entertained by the Township based on the assertion by the Respondent that he or she was uninformed as to any of the requirements of this RFT.

Should a Respondent find omissions from or discrepancies in this document or related documents, or should the Respondent be in doubt as to the meaning of any part of such documents, the Respondent should notify the contact identified in Section 2.13 without delay. If the Township considers that a correction, explanation or interpretation is necessary or desirable, an addendum will be issued as per Section 2.14 of this document. No oral explanation or interpretation will modify any of the requirements or provisions of the RFT documents.

## **2.13 Inquiries**

Inquiries concerning the RFT specifications and general RFT process are to be directed to:

Sherry Mulholland  
Deputy Treasurer

(705) 286-1260 ext. 501  
[smulholland@mindenhills.ca](mailto:smulholland@mindenhills.ca)

Questions of clarification will be answered individually, but response(s) to any question that modifies the scope of this RFT will be circulated as an Addendum as outlined in Section 2.12 of this document.

Inquiries must be received no later than **three (3)** business days prior to the closing date, on or before 12:00 noon, local time; otherwise a response may not be provided.

## 2.14 Addenda

If required by the Township, addenda will be distributed to all Respondents registered as a document taker (via the Township or on-line RFT provider) or invitational recipient for this RFT. Addenda will be distributed using the latest contact information as provided by the Respondent. It is the Respondent's responsibility to notify the Township of any changes to their contact information.

**If this document or related documents was acquired via the Township website it is the Respondent's responsibility to check the Township website at [www.mindenhills.ca](http://www.mindenhills.ca) for addenda. It is any and all Respondents ultimate responsibility to ensure all addenda have been received.**

All Respondents should check the Township website, on-line RFT provider or contact the Township directly as per Section 2.13 – Inquiries, prior to submitting their response to this RFT.

Respondents are required to acknowledge receipt of all addenda by signing the Acknowledgement of Receipt included on the addenda form. Failure to submit all addenda unless otherwise directed on the addenda form, **will constitute an automatic rejection.**

## 2.15 Acceptance or Rejection of Submission(s)

The Township reserves the right to reject or accept any or all submissions in whole or in part at any time without further explanation and to waive formalities as the interests of the Township may require without stating reasons thereto.

The Respondent acknowledges the Township's rights under this clause and absolutely waives any right of action against the Township's failure to accept its submission whether such right of action arises in contract, negligence, bad faith or any other cause of action.

The acceptance of any submission is subject to approval by the Township's Council.

Notwithstanding and without restricting the generality of the statements immediately above, the Township shall not be required to award and accept a submission:

- a) When only one (1) submission has been received as result of the RFT;
- b) Where the lowest responsive and responsible Respondent substantially exceeds the estimated cost of the work or goods and/or services;



- c) When all submissions received fail to comply with the specifications or terms and conditions;
- d) Where a change in the scope of work or provision of goods and/or services or specifications is required the lowest or any submission will not necessarily be accepted. The acceptance of a submission will be contingent upon an acceptable record of ability, experience and previous performance.

The Township shall not be responsible for any liabilities, costs, expenses, loss or damage incurred, sustained or suffered by any Respondent by reason of the acceptance or the non-acceptance by the Township of any submission or by reason of any delay in the acceptance of a submission except as provided in the RFT document.

Each submission shall be open for acceptance by the Township for a period of **sixty (60)** calendar days following the date of closing, or as otherwise mutually agreed to by each of the respondents.

Where the submission document does not state a definite delivery/work/provision of goods and/or services schedule and a submitted response is based on an unreasonable delivery/work/provision of goods and/or services schedule, the submission may be rejected.

## **2.16 Award Procedures**

The Township is not under any obligation to award the RFT and reserves the right at its sole discretion to terminate or amend this RFT at any time.

It is the intention of the Township to award this RFT to one (1) qualified Respondent. The lowest or any submission may not necessarily be accepted.

Unless stated otherwise the following procedures will apply:

The Township will notify the Successful Respondent that their submission has been accepted within one hundred twenty (120) calendar days of the RFT closing, or within three (3) business days of receiving Council approval, whichever is shortest.

Notice of acceptance of a Respondent's submission will be by telephone, email and/or by written notice. No further communication regarding this notice is required unless the Successful Respondent declines the awarding of this RFT.

Upon acceptance of the submission by the Township, the Successful Respondent shall provide the Township with any required documents within **fourteen (14)** calendar days of the date of notification of award or as otherwise specified in this document or related documents or by the Township.

Commencement and completion dates may be altered if mutually agreed to by the Township and the Successful Respondent.

## **2.17 Ability and Experience of Respondent**

It is not the purpose of the Township to award this RFT to any Respondent who does not furnish satisfactory evidence of possessing the ability and experience in this work or provision of goods and/or services and sufficient capital and plant resources to ensure

acceptable performance/product and completion/supply of the required specifications.

The following criteria will be utilized by the Township, through references provided in Appendix B – Experience, References & Contingencies, to determine whether a Respondent is qualified to undertake the award;

- The Respondent's ability and agreement to perform the work or supply the goods and/or services.
- The Respondent's ability to work effectively with the Townships' staff and other representatives.
- The Respondent's history with respect to providing satisfactory results and acceptable cooperation.

The Township may reject the lowest or any submissions, if after investigation and consideration, the Township concludes, in its opinion, that the Respondent is not able to perform the work or supply the goods and/or services in a manner satisfactory to the Township.

## **2.18 Variation of Quantities**

The Township reserves the right to adjust quantities. Quantities shown are approximate, are not guaranteed to be accurate and shall be used as a basis for comparison only. No additional compensation will be allowed for any adjustment which may decrease quantities identified in this document or related document(s).

## **2.19 Limited Liabilities**

The Township's liability under this RFT shall be limited to the actual work or goods and/or services ordered and provided.

## **2.20 Respondent Expense**

Any expenses incurred by the Respondent in the preparation of their submission are entirely the responsibility of the Respondent and will not be charged to the Township.

## **2.21 Contract Negotiations**

### **Submission as Binding Document:**

In the event that a Respondent's submission is accepted and confirmed in writing from the Township, the submission and the acceptance shall constitute a binding contract between the Successful Respondent and the Township, and the Successful Respondent shall complete the work or provision of goods and/or services as described in accordance with the provisions, specifications and conditions outlined in this document and other related documents and shall be binding upon the heirs, executors, administrators, successors and assigns of the Successful Respondent.

## **2.22 Conflict of Interest**

The Respondent shall declare any actual or potential conflict of interest that exists now or may exist in the future with respect to the Respondent's undertaking of the submission and, if selected, shall abstain from taking on work or the provision of goods and/or

services which would represent a conflict of interest over the duration of this work or provision of goods and/or services.

The Respondent shall declare that the response submitted is in all respects fair and without collusion or fraud and further that no member of Council, Officer or employee of the Township has become interested, directly or indirectly, as a contracting party, partner, stockholder, surety or otherwise, regarding the work or provision of goods and/or services identified in this RFT.

The Township reserves the sole right and discretion to determine whether any situation constitutes an actual or potential conflict of interest and may disqualify any Respondent on such basis.

## **2.23 Freedom of Information**

Any personal information required on the submission is received under the authority of the *Municipal Freedom of Information and Protection of Privacy Act, 1989, RSO, 1990 (Act)*. This information forms an integral component of the RFT submission.

All submissions received by the Township become a public. All information contained in the submission document is available to the public, including personal information.

Questions regarding collection of personal information and the *Municipal Freedom of Information and Protection of Privacy Act, 1989, R.S.O. 1990, Chapter M.56*, as amended, should be directed to:

Clerk, Township of Minden Hills  
7 Milne Street, PO Box 359  
Minden, ON  
K0M 2K0  
Telephone (705) 286-1260

The Clerk has been designated by the Township's Council to carry out the responsibilities of the Act.

## **2.24 Package Submissions Information Release to Other Respondents**

The number of RFTs received and the names of the Respondents are confidential and shall not be divulged prior to the public RFT opening.

Subsequent to the opening, however, the number of RFT packages released is public information. It is understood that by completing and submitting a response the Respondent agrees to the public release of their name.

## **2.25 Access to Information**

The disclosure of information received relevant to the issue of a RFT solicitation or the award of contracts emanating from such solicitations shall be made by the appropriate offices in accordance with the provisions of the *Municipal Freedom of Information and Protection of Privacy Act, R.S.O. 1990*, as amended.

All records and information pertaining to tenders, proposals and other sealed bids, which reveal a trade secret or scientific, technical, commercial, financial or other labour

relations information supplied in confidence implicitly or explicitly, shall remain confidential if the disclosure could reasonably be expected to:

- a) Prejudice significantly the competitive position or interfere significantly with the contractual or other negotiations of a person, group of persons, or organizations;
- b) Result in similar information no longer being supplied to the Township where it is in the public interest that similar information continues to be so supplied;
- c) Result in undue loss or gain to any person, group, committee or financial institution or agency; or
- d) Result in information whose disclosure could reasonably be expected to be injurious to the financial interests of the Township.

## **2.26 Warranty**

The product bid, shall include a 3-Year Warranty, including any/all manufactured defects.

## 3 Contractual Requirements

---

### 3.1 Occupational Health and Safety

All work performed under this RFT must be carried out in accordance with the terms and conditions of the Occupational Health & Safety Act, R.S.O. 1990, as amended and any other applicable legislation.

Failure to comply with Safety Regulations, as set out in this document, may result in the immediate cancellation of the work.

The Successful Respondent must comply with all requirements set out in the *Occupational Health & Safety Act, R.S.O. 1990* and all other regulations that apply to the job at hand. The following language, requirements and conditions shall apply:

Where applicable under the Occupational Health and Safety Act (OHSA) (R.S.O.1990 C. 0.1) and regulations, made under that statute:

- a. Successful Respondents acknowledge that they have read and understood the Occupational Health and Safety Act (OHSA) (R.S.O. 1990 C. 0.1) and regulations, made under that statute.
- b. The Successful Respondent shall comply with all health and safety requirements established by the Occupational Health and Safety Act and regulations, the Township and any applicable industry standards. The selected Respondent agrees to assume full responsibility for the enforcement of same.
- c. The Successful Respondent may be required to participate in a pre-project meeting to verify its full understanding of the major contractual requirements and expectations in the area of health and safety before the start of any work.
- d. The Successful Respondent shall understand that its performance will be monitored and that their overall performance will be a major consideration for future contracts with the Owner. The frequency and detail of ongoing project monitoring will be dependent upon the nature of the work and safety precautions specified.
- e. The Successful Respondent shall allow access to the work site on demand to representatives of the Township.
- f. The Township will take all action necessary to support the Successful Respondents health and safety efforts and to ensure that the Township owned and controlled environments in the vicinity of the project are free from hazards.
- g. The Successful Respondent acknowledges and agrees that any breach or breaches of health and safety requirements, whether by the selected Respondent or any of its sub-selected Respondents may invalidate the contract.
- h. The Successful Respondent acknowledges and agrees that any damages or fines that may be assessed against the Township by reason of a breach or breaches of the OHSA by the Successful Respondent or any of its sub-Successful Respondents will entitle the Township to set off the damages so

assessed against any monies that the Township may from time to time owe the Respondent under this contract or any other contract whatsoever.

- i. The Successful Respondent shall provide a list of all controlled hazardous materials or products containing hazardous materials, all physical agents or devices or equipment producing or omitting physical agent and any substance, compound, product or physical agent that is deemed to be or contains a designated substance in accordance with the Global Harmonized System (GHS – formally known as WHIMIS ) as defined under the Occupational Health and Safety Act and shall provide appropriate Material Safety Data Sheets for these substances used for the performance of the required work, all prior to the performance of said work.
- j. Where hazardous materials, physical agents and/or designated substances are used in the performance of the required work, the Successful Respondent shall ensure that the requirements of the Occupational Health and Safety Act and associated regulations are complied with.
- k. The Successful Respondent shall follow Global Harmonized System (GHS) requirements and ensure all employees are given required training and support.
- l. The Successful Respondent shall have a clearly defined safety plan/rescue plan for its workers involved in hazardous activities.
- m. The Successful Respondent agrees at all times to comply with Occupational Health and Safety Standards in the workplace and further agrees to adhere to Health and Safety Standards set out in applicable statutes and regulations and to comply with written Health and Safety Policies of the Township.
- n. Successful Respondents with known poor safety records or with inadequate qualifications or equipment will not be considered for award.
- o. Worker safety is given first priority in planning, pricing and performing the Work;
- p. Its officers and supervisory employees have a working knowledge of the duties of a Constructor and Employer under the Act and the provisions of the Regulations applicable to the Work, and a personal commitment to comply with them;
- q. Workers employed to carry out the Work possess the knowledge, skills and protective devices required by law or recommended for use by a recognized industry association to allow them to work in safety;
- r. Its supervisory employees carry out their duties in a diligent and responsible manner with due consideration for the health and safety of the workers; and
- s. All subcontractors employed by the Successful Respondent to perform part of the Work and their employees are properly protected from injury while carrying out their associated duties.

### **3.2 Workplace Safety Insurance Board (WSIB)**

All Respondents must indicate WSIB coverage by providing their certificate number, or indicate exemption from coverage as per the *Workplace Safety and Insurance Board*,

on Appendix A – Submission Requirements.

The Successful Respondent shall provide proof of coverage and shall maintain this coverage throughout the length of the contract, work or provision of goods and/or services.

If exempt from coverage, the Successful Respondent shall obtain optional coverage in the form of a letter from WSIB and must be provided to the Township within ten (10) business days of being awarded or commencement of the contract, work or provision goods and/or services, whichever is shortest.

The Successful Respondent may request an extension, providing valid and reasonable claims for the request. Requests for an extension shall be made in writing or by email to the contact noted in Section 2.13 – Inquiries. Failure to meet the extension date as approved by the Township may result in the cancellation of the contract, work or provision goods and/or services. Refer to Section 3.12.4 – Cancellation of Contract.

### **3.3 Indemnification**

The Successful Respondent shall indemnify and hold harmless The Township, its officers, council members, partners, agents and employees from and against all actions, claims, demands, losses, costs, damages, suits or proceedings whatsoever which may be brought against or made upon The Township and against all loss, liability, judgments, claims, suits, demands or expenses which The Township may sustain, suffer or be put to resulting from or arising out of the Successful Respondent's failure to exercise reasonable care, skill or diligence or omissions in the performance or rendering of any work or provision of goods and/or services required hereunder to be performed or rendered by the Successful Respondent, its agents, officials and employees.

### **3.4 Force Majeure**

The Successful Respondent shall not be assessed with liquidated damages for any delay caused by Acts of God or of the Public Enemy, Acts of the Province or of any Foreign State, Fire, Flood, Epidemics, Quarantine, Restrictions, Embargoes, Labour Disruptions, Strikes, Lockouts or delays due to such causes, then the time of delivery shall be extended for a period of time equal to the time lost to such delay.

### **3.5 Insurance Requirements**

All Respondents will acknowledge their ability to provide proof of insurance in accordance with this document and other related documents, identified in Appendix A – Submission Requirements.

All insurance costs related below will be borne by the Successful Respondent.

The Successful Respondent, as a minimum, shall provide and maintain during the term of the Contract:

#### Specific Conditions:

- a) Commercial General Liability insurance applying to all operations of the Successful Respondent which shall include coverage for bodily injury or

death, broad form property damage, products and completed operations liability, owner's & contractor's protective liability, blanket contractual liability, contingent employer's liability, non-owned automobile liability and shall include cross liability and severability of interest clauses. Such policy shall be written with limits of not less than FIVE MILLION DOLLARS (\$5,000,000.00) exclusive of interest or costs, per occurrence and shall include **The Corporation of the Township of Minden Hills** as an additional insured.

General Conditions:

- a) The Successful Respondent shall provide proof of insurance in the form of a Certificate of Insurance.
- b) All policies shall be endorsed to provide the Township with not less than 30 Days' written notice of cancellation.
- c) All policies shall be with insurers licensed to underwrite insurance in the Province of Ontario with an AM Best rating of no less than A-.
- d) Prior to commencement of work or the provision of goods and/or services and upon the placement, renewal, amendment, or extension of all or any part of the insurance, the Successful Respondent shall promptly provide the Township with confirmation of coverage and, if required, a certified true copy(s) of the policy(s) certified by an authorized representative of the insurer together with copies of any amending endorsements applicable to the supply of work or the provision of goods and/or services.
- e) All applicable deductibles under the above required insurance policies are at the sole expense of the Successful Respondent.
- f) All policies shall apply as primary and not as excess of any insurance available to the Township.
- g) It is expected by the Township that the Certificate(s) of Insurance will provide confirmation that all insurance requirements as stated above have been met.
- h) Insurance must remain in effect for the duration of the contract, Work or provision of Goods and/or Service(s) as per the terms of this document and other related documents. It will be the responsibility of the Successful Respondent to provide the Township with any and all renewal certificates during this period.

The certificate of insurance must be provided to the Township within five (5) business days of being awarded the successful submission and/or contract, or prior to commencement of the contract, work or provision of goods and/or services, whichever is shortest. Failure to submit the requested insurance certificate by the Successful Respondent shall result in a withdrawal of the contract, work and/or provision of goods and/or services by the Township.

The Successful Respondent may request an extension, providing valid and reasonable claims for the request. Requests for an extension shall be made in writing or by email to the contact noted in Section 2.13 – Inquiries. Failure to meet the extension date as approved by the Township may result in the termination of the



contract, work or provision of goods and/or services.

### **3.6 Protection of Work and Property**

The Successful Respondent shall provide continuous and adequate protection of all goods from damage and shall protect the Township's property from injury or damage arising until the work or provision of goods and/or services is complete. The Successful Respondent shall make good any such damage or injury.

### **3.7 Regulation Compliance and Legislation**

The Successful Respondent shall ensure all work or provision of goods and/or services are in accordance with, and under authorization of all applicable authorities, Municipal, Provincial and Federal legislation.

### **3.8 Workplace Violence and Harassment**

The Successful Respondent shall comply with the Occupational Health and Safety Act, Canada Criminal Code, Ontario Human Rights Code and all other applicable legislation and/or regulations, as they relate to violence, harassment and sexual harassment in the workplace.

### **3.9 Code of Conduct**

Successful Respondents hired/contracted/engaged by the Township shall endeavor to at all times promote a high level of ethical conduct by themselves and their employees. In acting on behalf of the Township, no Successful Respondent, or their employees, shall at any time take any action which he or she knows, or reasonably should know, violates any applicable law or regulation.

The Township requires that Successful Respondents and their employees shall maintain high standards of professional behaviour when dealing with Members of Council, Officers of the Corporation, other Township employees, clients and the public; and further that this behaviour shall reflect positively on the reputation of the Township.

It is every Successful Respondent, and their employee's, responsibility to ensure that all information communicated is as accurate as reasonably possible. No Successful Respondent, or their employees, shall withhold information or willfully mislead Members of Council, officers, employees, clients, or the public about any issue of corporate concern.

Every Successful Respondent, and their employee's shall respect the rights, privileges, diversity and dignity of the persons they interact with while contracted by the Township.

### **3.10 Smoke Free Workplace**

The Smoke-Free Ontario Act, 2017 prohibits smoking in any enclosed workplaces, including work vehicles and any enclosed public places in Ontario in order to protect workers and the public from the hazards of second-hand smoke.

During the duration of the contract, work or provision of goods and/or services, including any related amendments and/or extensions, Successful Respondents, and their employees, shall adhere to the Smoke Free Ontario Act, 2017 and all other applicable

legislation and/or regulations or requirements, in regards to cigarette, e cigarette and cannabis use.

### **3.11 Accessibility**

Under the Accessibility for Ontarians with Disabilities Act, 2005, S.O 2005, c. 11 (AODA), the Township is required to incorporate accessibility criteria, features and designs when procuring or acquiring goods, services, self-service kiosks or facilities, including written materials, web content and the delivery of programs, except where it is not practicable to do so. Contract specifications and evaluation include these criteria, features and designs where applicable.

[The Accessibility for Ontarians with Disabilities Act, 2005, S.O. 2005, c. 11](#) (AODA) and [Regulation 191/11 Integrated Accessibility Standards](#) (IAS), requires anyone who provides goods, services or facilities on behalf of the Township to receive training on these standards and on the [Human Rights Code](#) as they pertain to persons with disabilities.

Successful Respondents must keep records of all training, including dates when training was provided, the number of employees who received training and individual training records for their business. Successful Respondents are required to make this information available to the Township and/or the Province upon request.

An online [Serve-Ability](#) e-course is available for free and includes the Province's IAS training. It is the responsibility of the Successful Respondent to ensure they have read and understand the Act, Regulations and training in regards to persons with disabilities.

Web links for information and training purposes are provided below:

- AODA - <https://www.ontario.ca/laws/statute/05a11>
- IAS - <https://www.ontario.ca/laws/regulation/110191>
- Human Rights Code - <https://www.ontario.ca/laws/statute/90h19?search=e+laws>
- Serve-Ability - [https://www.ocapdd.on.ca/Forms/Volunteer/SAE/HTML\\_Eng/index.html](https://www.ocapdd.on.ca/Forms/Volunteer/SAE/HTML_Eng/index.html)
- AccessON - <https://accessontario.com/>

More information on these subjects can be found on our municipal website at [www.mindenhills.ca](http://www.mindenhills.ca), the [Regulation 191/11 Integrated Accessibility Standards](#), Accessibility Ontario website at [AccessON](#), and available from the Ministry of Economic Development, Employment & Infrastructure's website, the link is provided below: (<http://www.mcass.gov.on.ca/en/mcass/programs/accessibility/ado.aspx>).

### **3.12 Contract**

The Successful Respondent shall complete the work as described in accordance with the provisions, specifications and conditions outlined in the RFT documents and shall be binding upon the heirs, executors, administrators, successors and assigns of the Successful Respondent.

### **3.12.1 Assignment of Contract**

The Successful Respondent shall not assign transfer, convey, sublet or otherwise dispose of the contract, work or provision of goods and/or services; or his/her right, title or interest therein, or his power to execute such contract, work and/or provision of goods or services, to any other person, company or corporation, without the previous consent, in writing, of the Township's officials.

### **3.12.2 Sub-Contracting**

The Successful Respondent, who has signed a contract with the Municipality, shall be considered to be the "prime contractor" and shall keep the operation totally under their care and control. The consent of the Municipality for assignment or sub-contracting shall not relieve the "prime contractor" from completion of the specifications of this RFT in accordance with the terms of the contract, the work or the provision of goods and/or services. Where a Successful Respondent submits a joint proposal or proposes a partnership arrangement, the Successful Respondent must assume the lead or "prime contractor" position. As such, the Successful Respondent will have the overall responsibility for completing the contract, work or provision of goods and/or services.

### **3.12.3 Contract Amendments and Revisions**

No amendment or revision to a contract, the work or the provision of goods and/or services shall be made unless mutually agreed to by the Township and the Successful Respondent.

No amendment that changes the price of a contract, the work or the provision of goods and/or services shall be agreed to without a corresponding change order describing the change in requirement or scope of work or the provision of goods and/or services.

Amendments to a contract, the work or the provision of goods and/or services are subject to the identification and availability of sufficient funds in appropriate accounts within the Township's Council approved budget, including authorized revisions.

The Township reserves the right to change the term of the contract, the work or the provision of goods and/or services prior to the execution of an agreement, or commencement of the work or provision of goods and/or services.

### **3.12.4 Cancellation of Contract**

The Township reserves the right to immediately terminate the contract, the work or the provision of goods and/or services awarded to the Successful Respondent, or part thereof, at its own discretion, including but not limited to such items as non-compliance, non-performance, late deliveries, inferior quality, pricing problems, etc.

The Township shall not be liable to the Successful Respondent for loss of anticipated profit on the cancelled portion or portions of the work or the provision of goods and/or services.

## **3.13 Conflict of Interest**

The Successful Respondent shall declare any actual or potential conflict of interest that exists now or may exist in the future with respect to the Respondent's undertaking of the

work or provision of goods and/or services and shall abstain from taking on work which would represent a conflict of interest over the duration of a Contract, the work or the provision of good and/or services.

### **3.14 Bankruptcy**

In the event that, during the duration of a contract, the work or the provision of goods and/or services, the Successful Proponent Respondent makes an assignment for the benefit of creditors, or becomes bankrupt or insolvent, or makes a proposal to its creditors, a contract, the work or the provision of goods and/or services shall immediately be terminated, and the Township shall be entitled to enter into a contract, the work or the provision of goods and/or services with another party without the consent of the Successful Respondent.

### **3.15 Governing Laws**

A contract, the work or the provision of goods and/or services will be interpreted and governed by the laws of the Province of Ontario.

### **3.16 Delivery and Execution of Work**

The Successful Respondent may commence work as soon as notification of award. Work must be completed and units must be delivered to the Scotch Line Landfill, 2038 Scotch Line Road, by July 31, 2023 or as mutually agreed with the Director of Public Works, or designate(s), and Successful Respondent.

### **3.17 Pre-Start Meeting**

A pre-start meeting is not required.

### **3.18 Terms of Payment**

Payment will be made in response to the Successful Respondent's approved invoice to the Township.

The Township will not pay in part or in full until the contractual work or provision of goods and/or services is complete/received.

Unless otherwise stated herein, the Township's normal terms of payment will be net thirty (30) calendar days from the completion of work or provision of goods and/or services or the date of approved invoice, whichever occurs later. Invoices shall be forwarded to the attention of:

Accounts Payable  
Township of Minden Hills  
7 Milne Street, PO Box 359  
Minden, ON  
K0M 2K0  
[accountspayable@mindenhills.ca](mailto:accountspayable@mindenhills.ca)

### **3.19 Settlement of Disputes**

Until the contract, work or provision of goods and/or services has been terminated, the Successful Respondent must at all times provide the work or provision of goods and/or services. If there is a dispute or difference concerning the work or provision of goods and/or services or the interpretation of the contract, work or provision of goods and/or services then either party may notify the other that it wishes the dispute to be referred to a meeting with the Director of Public Works and the Successful Respondent to resolve, negotiating in good faith.

### **3.20 Guarantee of Performance**

The Successful Respondent guarantees that all work, goods and/or services will be carried out as specified, and that the Successful Respondent will, at the Successful Respondent's own expense, correct all deficiencies in a manner satisfactory to the Township, for which the Successful Respondent is held responsible by the Township, and the decision of the Township in all such matters shall be final.

In the event of a multi-year award and/or contract, the Township reserves the right to terminate the contract, Work or provision of Goods and/or Service(s) at any time during the term of the contract, Work or provision of Goods and/or Service(s) due to the unsatisfactory performance of the Successful Respondent.

The Township may, without prejudice to any other remedy, correct the following:

- If the Successful Respondent fails to perform the work or provide the goods and/or services in accordance with its obligations under a contract or the award of work or the provision of goods and/or services.
- If there exists unsatisfied claims for damages caused by the Successful Respondent to anyone on the site or in connection with the work or provision of goods and/or services.
- Where there are affidavits of claim of lien, or liens filed against the site and premises on which the work or provision of goods and/or services is done or being done, or reasonable evidence of the probable filing of such affidavits of claim of lien or of filing or registration of liens.

### **Township's Right to Remedy Default in Provision of Services**

If the Successful Respondent should neglect to execute the work or provision of goods and/or services properly (a default), after **three (3)** business days written notice to the Successful Respondent setting out the particulars of the default, the Township may remedy the default of the Successful Respondent at the sole cost and expense of the Successful Respondent.

The Township shall have the authority and discretion to retain a contractor or firm to undertake the necessary work or provision of goods and/or services to remedy the default(s) set out in the foregoing notice at the sole cost and expense of the Successful Respondent.

The Successful Respondent acknowledges and agrees that the Township shall have the authority to deduct from any payments owing to the Successful Respondent, the costs invoiced to the Township by the firm retained to remedy the default of the Successful Respondent plus a 10% administration charge (based upon amount of such invoice pre-H.S.T.). Where no payment is owing, the Township shall invoice the Successful Respondent. The Successful Respondent agrees to pay the Township, without the right to dispute the amounts invoiced, within 15 days of the date of such invoice.

The Township's authority remedy default hereunder is without prejudice to any other remedy, action or other alternative that may be available to the Township. Continued failure of the Successful Respondent to execute the work or provision of goods and/or services properly shall result in a termination of contract, work or provision of goods and/or services. The Township shall provide written notice of termination.

### **3.21 Successful Respondent Performance Evaluation**

Successful Respondent performance is critical to the success of the Township. To this end, the Township reserves the right to assess future RFTs submissions by the Successful Respondent based on the terms of a contract, the performance of work or the provision of goods and/or services, as awarded and as related to the specifications and requirements of this RFTs; as well as any outcomes identified as a result of the requirements noted in Section 3.18.

### **3.22 Taxes**

Unless otherwise provided herein, the Successful Respondent shall pay all government sales or excise taxes in force at the date of the contract, work or provision of goods and/or services, provided that any increase or decrease in such taxes shall increase or decrease the amount due/payable. Invoices shall show the appropriate amounts for the work or provision of goods and/or services and applicable taxes separately.

### **3.23 Notices**

Any notice required to be given or made shall be given or made in writing and shall be served personally or mailed by registered mail addressed to the Township of Minden Hills and to the Successful Respondent at the address set forth in its submission.

## 4 RFT Specifications

---

### 4.1 Overview

The Township is seeking qualified bidders to manufacture and deliver steel plates to be used as an alternative to sand cover at the Scotch Line Landfill. The steel cover plates must be durable, be made from solid steel with no holes and be equipped with hooks that the bucket of an excavator will use to lift the plate.

A photograph of an example cover plate is included as Appendix I to this RFT for reference. The Township is flexible with the final design of the plate and does not require the final product to reflect this photograph precisely. The plates must meet the specifications in Section 4.2.

### 4.2 Specifications

The Successful Respondent will manufacture and deliver to the Township three (3) steel cover plates consisting of a frame, a solid face plate and hooks for lifting with an excavator.

Cover plates are to be 3m wide x 6m long (10 feet wide x 20 feet long) including the frame.

Cover plates are to be constructed with a frame to provide stability such that the plates don't warp or bend. The frame is to be constructed such that if the cover plates were stacked one on top of the other, the hooks on the bottom steel plate would fit fully under the steel plate placed on top of it. The frame may be constructed of tubular steel.

The face plate must be made of a solid 2cm (3/4") thick steel plate with no holes/grating.

All exposed surfaces shall be painted using an industry standard zinc rust inhibiting paint/primer, bright yellow in colour.

A minimum of two hooks must be installed in the middle of the cover plate, similar to the photo shown in Appendix I – Sample Photos. The hooks will be used by an excavator to lift the cover plate and so should be constructed of durable material and attached in such a fashion that the hook will withstand the torque created by the lift of the excavator and the pull of the plate away from the machine. The excavator bucket is equipped with teeth, and as such, the hooks must be spaced such a distance apart that the hooks will fit between the teeth. Diagrams of the excavator bucket with measurements are included in Appendix J.

The maximum weight of each plate may not exceed 5,500kg (11,900lb).

The plates must be delivered to the Scotch Line Landfill, located at 2038 Scotch Line Road, Minden ON by October 31, 2023. An excavator and operator will be available to assist with unloading.

### 4.3 Respondent Experience

The Respondent shall submit Appendix B – Experiences, References & Contingencies that provides three references who can speak to the Respondent's ability to provide the services requested in this document. With Appendix B, the respondent shall also

provide a brief contingency plan detailing how materials will continue to be provided to the Township for the duration of the contract in the event that equipment failure, staffing issues or supply shortages impact the Respondent's operation.

#### 4.4 Respondent Responsibilities

The Successful Respondent will be responsible for:

- Supply of all equipment and materials required to fulfill manufacturing of the steel landfill cover plates described within.
- Delivery of steel cover plates to the Scotch Line Landfill by October 31, 2023.

#### 4.5 Township Responsibilities

The Township will provide:

- An excavator and operator to assist with unloading at the Scotch Line landfill.

#### 4.6 Pricing Requirements

Respondents shall provide a unit price per plate and a delivery fee as per the requirements of Appendix F – Price & Delivery Schedule.

Any change work orders or work additional to this RFT shall be agreed to by the Township prior to the execution of the proposed works.

During the award process the Township reserves the right to exclude any component of the RFT.

#### 4.7 General Instructions

For each Specification item listed, you are required to indicate your compliance of each item. Please do so as follows:

You are able to provide the item as specified - indicate **YES** in the Respondent's Compliance box.

You are not able to provide the item as specified - indicate **NO** in the Respondent's Compliance box.

Where an item allows for an "Alternative" to the specified item, you may indicate **YES** to the item as specified or you may provide your **alternative item** in the Respondent's Comment box.

Where minimums are called for, the item must meet or exceed the capacity, size or performance as specified, unless an alternative is allowed. This specification may list only the major details for the specification items. Therefore, it is the Respondent's responsibility to deliver fully equipped items with compatible components to provide dependable efficient service:

#### 4.8 Other Instructions

Responses to this RFT must include Mandatory Appendices noted as "Mandatory Completion" and/or "Mandatory Submission".



## **4.9 Cooperative Purchasing**

The Successful Respondent agrees to allow public agencies with similar needs/interests to participate in this contract.

Additional participating agencies may opt into a contract with the successful respondent for procurement of services described in this RFP based on the terms, conditions, prices and percentages offered to the Township of Minden Hills with changes negotiated as required, due to location and quantity of work.

This piggyback clause is intended to be a means of promoting cooperative purchasing efforts with the public sector, and to provide additional value to the successful respondent. Any cost savings associated with cooperative purchasing shall be separately identified within the tender document.

## 5 Evaluation Process

---

Respondents acknowledge that submissions are likely to be drafted using a diverse range of approaches and, therefore, may not be readily comparable to one another. As a result, notwithstanding the application of consistent evaluation criteria as identified below, the Township shall use professional discretion in evaluating proposals.

The Township retains the right to ask Respondents for clarification regarding their submission, if doing so does not change their proposal in any way.

### 5.1 Evaluation Stages

The Township will conduct the evaluation of this RFT in three (3) stages as follows:

#### Stage 1 – RFT Review (pass/fail)

A review will be undertaken to determine if the submitted Tender complies with all the mandatory requirements (inclusion of all Appendices and compliance with Appendix A - Submission Requirements and deadline).

Tenders that do not comply with the mandatory requirements shall, subject to the reserved rights of the Township of Minden Hills and the Township's Procurement Policy, be disqualified and not evaluated further.

#### Stage 2 – Pricing (100 points)

Stage 2 will consist of a scoring of the pricing submitted on Appendix F – Price & Delivery Schedule. The evaluation of the price/cost shall be undertaken only after the first stage has been completed. Only those Bidders who move forward from Stage 1 will be scored here.

Each Bidder will receive a percentage of the total possible **100** points allocated to price by dividing the Bidder's price into the lowest tender of the short-listed Bidders.

For example, if the lowest Tender price is \$120.00, that Bidder received 100% of the points ( $120/120 = 100\%$ ), or **100** points. A Bidder who Tenders \$150 receives 80% of the possible points ( $120/150 = 80\%$ ) or **40** points. A Bidder who Tenders \$240 receives 50% of the possible points ( $120/240 = 50\%$ ) or **25** points.

Respondents should be aware that this is a "gated process". Submissions will be initially evaluated on non-price based criteria first. From there, the highest scoring submissions will be chosen to have their pricing evaluated in order to arrive at a total aggregate score for the best solutions.

#### Stage 3 – References (Pass/Fail)

Stage 3 may consist of the Township verifying references and experience of the preferred bidder.

At this stage, the Director of Public Works or designate may verify as many references provided by the preferred Bidder as provided on Appendix B as is deemed appropriate and

such references may be conducted via email, telephone, and/or in-person as the Director of Public Works may determine in his sole discretion.

References will be assessed on a pass/fail basis as to their satisfaction with the previous work performed, and will serve to validate (or not, as the case may be) the evaluation conducted by the Director of Public Works.

## 5.2 Total Evaluation Points Available

Overall, a Respondent may receive a maximum of **100** Evaluation points as follows:

<b>Criteria</b>	<b>Maximum Points</b>
Stage 1 - Compliance with Submission Requirements	Pass/Fail
Stage 2 – Contract Price Evaluation	100
Stage 3 – Reference/Experience Verification	Pass/Fail
<b>Total</b>	<b>100</b>

As a result of this process, the Township may not accept the lowest or any bid.

## 6 Appendices

### 6.1 Appendix A – Submission Requirements

**\*\*MANDATORY COMPLETION\*\***

All Respondents are required to successfully meet the mandatory requirements described in the following table and **submit with their response**, proof of meeting these requirements. Failure to meet the requirements under this Appendix will constitute in an automatic rejection.

Specification		Mandatory/ Optional/Preferred	Respondent's Compliance (see also WSIB & Insurance Acknowledgement below)
1	WSIB (Section 3.2) Account #:  _____ OR Check here if exempt from WSIB coverage as described in Section 3.2 of this document.	Mandatory	Yes <input type="checkbox"/> No <input type="checkbox"/>
2	Insurance and Indemnification requirements as described in Sections 3.3 and 3.5 of this document where applicable.	Mandatory	Yes <input type="checkbox"/> No <input type="checkbox"/>
3	Product/Workmanship Warranty as described in Section 2.26 of this document.	Mandatory	Yes <input type="checkbox"/> No <input type="checkbox"/>
4	Submission of all other required Appendices.	Mandatory	Yes <input type="checkbox"/> No <input type="checkbox"/>
5	Two (2) hardcopies of the completed submission.	Mandatory	Yes <input type="checkbox"/> No <input type="checkbox"/>

#### **WSIB and Insurance Acknowledgement**

By signing below, I \_\_\_\_\_, acknowledge  
that  
Name of individual

\_\_\_\_\_ has the ability to provide the requested WSIB, and  
Name of Company

Insurance certificate(s) in accordance with this RFT document.

\_\_\_\_\_  
Signature

\_\_\_\_\_  
Date

## 6.2 Appendix B - Experience, References & Contingencies

**\*\*MANDATORY COMPLETION\*\***

Three (3) references **must** be provided as per the table below for the purpose of assessing the Respondent's ability and experience.

1. References		
No.1	Name:	
	Contact Name & Title:	
	Phone No.:	
	Term of Contract:	
	Nature of Contract:	
No.2	Name:	
	Contact Name & Title:	
	Phone No.:	
	Term of Contract:	
	Nature of Contract:	
No.3	Name:	
	Contact Name & Title:	
	Phone No.:	
	Term of Contract:	
	Nature of Contract:	

### 6.3 Appendix C - Suppliers & Subcontractors

**\*\*MANDATORY COMPLETION\*\***

Please provide information on the suppliers and/or subcontractors as it will apply to your tender submission. If there are none, please submit N/A.

<b>Suppliers</b>
<b>Supplier No.1</b> Name: Contact Name & Title: Address: Phone No.: Nature of goods/services supplied:
<b>Supplier No.2</b> Name: Contact Name & Title: Address: Phone No.: Nature of goods/services supplied:
<b>Contractors</b>
<b>Subcontractors No. 1</b> Name: Contact Name & Title: Address: Phone No.: WSIB: Insurance: Nature of Work to be Subcontracted:
<b>Subcontractors No. 2</b> Name: Contact Name & Title: Address: Phone No.: WSIB: Insurance: Nature of Work to be Subcontracted:

## 6.4 Appendix D - Respondent Information

**\*\*MANDATORY COMPLETION\*\***

Information provided must be legible and made in a non-erasable medium.

<b>Respondent's Contact Individual</b>	
<b>Office Phone #</b>	
<b>Toll Free #</b>	
<b>Cellular #</b>	
<b>Fax #</b>	
<b>E-mail address</b>	
<b>Website</b>	
<b>HST Account #</b>	
<b>1<sup>st</sup> Emergency Contact Name</b>	
<b>1<sup>st</sup> Emergency Contact Phone #</b>	
<b>2<sup>nd</sup> Emergency Contact Name</b>	
<b>2<sup>nd</sup> Emergency Contact Phone #</b>	

## 6.5 Appendix E – Declaration Form

**\*\*MANDATORY COMPLETION\*\***

<b>For the provision of:</b>	<b>Steel Landfill Cover Plates</b>			
<b>As supplied by:</b>	_____			
	Firm Name			
	_____			
	Mailing Address	City	Prov.	Postal Code

<b>To:</b>	Township of Minden Hills			
	7 Milne Street, PO Box 359			
	Minden, ON, KOM 2K0			

### The Respondent Declares:

1. No person(s), firm or corporation, other than the Respondent, has any personal interest in this RFT or in the award for which this RFT is made;
2. No member of Council, no officer or employee of the Township is or will become interested directly or indirectly as a contracting party, partner, shareholder, surety or in any portion of the profits thereof, or in any of the monies to be derived, there from;
3. This submission is made without any connection, comparison of figures, or arrangements with, or knowledge of any other corporation, firm or person making a submission for the same and is in all respects without collusion or fraud;
4. The response submitted is in all respects without conflict of interest, fair and without collusion or fraud and further that no member of Council, Officer or employee of the Township has become interested, directly or indirectly, as a contracting party, partner, stockholder, surety or otherwise, regarding the work or provision of goods and/or services identified in this RFT.
5. By signing this submission, I confirm I have read, understood and accept the content, stipulations and requirements of this RFT document.

### LOWEST OR ANY SUBMISSION NOT NECESSARILY ACCEPTED

Dated at \_\_\_\_\_ this \_\_\_\_\_ day of \_\_\_\_\_, 20\_\_

\_\_\_\_\_  
PRINT NAME OF WITNESS

\_\_\_\_\_  
PRINT NAME OF RESPONDENT

\_\_\_\_\_  
SIGNATURE OF WITNESS

\_\_\_\_\_  
SIGNATURE OF RESPONDENT

By my signature, I hereby confirm I am a principal, or have been duly authorized by the principal/board, to sign on behalf of the above named.



**6.6 Appendix F - Price & Delivery Schedule**

**\*\*MANDATORY COMPLETION\*\***

**Table 1: Contract Pricing Table**

Item	Unit Price	Quantity	Extended Price (unit price x quantity)
Cover Plate		3	
Delivery		1	
<b>Subtotal</b>			
<b>HST</b>			
<b>Total</b>			

## 6.7 Appendix G - Guarantee of Performance/Cancellation of Contract or Provision of Goods and/or Services

### **\*\*MANDATORY COMPLETION\*\***

The Contractor guarantees that all work or provision of goods and/or services will be carried out as specified in the RFT, and that the Successful Respondent will, at the Successful Respondent's own expense, correct all deficiencies in a manner satisfactory to the Township, for which the Successful Respondent is held responsible by the Township, and the decision of the Township in all such matters shall be final.

In the event of a multi-year award and/or contract, the Township reserves the right to terminate the contract, Work or provision of Goods and/or Service(s) at any time during the term of the contract, Work or provision of Goods and/or Service(s) due to the unsatisfactory performance of the Successful Respondent. The Township may, without prejudice to any other remedy, correct the following:

- If the Successful Respondent fails to perform the work in accordance with its obligations under the contract or provision of good and/or services.
- If there exists unsatisfied claims for damages caused by the Successful Respondent to anyone on the Site or in connection with the work or the provision of goods and/or services.
- Where there are affidavits of claim of lien, or liens filed against the site and premises on which the work or provision of goods and/or services is done or being done, or reasonable evidence of the probable filing of such affidavits of claim of lien or of filing or registration of liens.

### **Acknowledgement**

I \_\_\_\_\_, confirm that I have read, understand and agree to the requirements outlined in Appendix G – Guarantee of Performance/Cancellation of contract, work or provision of goods and/or services.

---

Signature

---

Date

## 6.8 Appendix H - Agreement Acknowledgement

### **\*\*MANDATORY COMPLETION\*\***

In the event that the Township of Minden Hills wishes to enter into a Contract Agreement with the Successful Respondent for the provision of Steel Landfill Cover Plates for the Township, upon final approval from Council.

Sections; 3 (Contractual Requirements), 4 (Specifications-from submission), and 6 (Appendices-from submission) will form part of the agreement document.

The Successful Respondent hereby acknowledges, by signing below, that any information included in the submission, including the RFT document, Form of RFT, Appendices and/or other submission requirements, will become public information and form part of the completed Contract Agreement.

In the event that a Respondent's submission is accepted and confirmed in writing from the Township, the submission and the acceptance shall constitute a binding contract between the Successful Respondent and the Township, and the Successful Respondent shall complete the work or provision of goods and/or services as described in accordance with the provisions, specifications and conditions outlined in this document and other related documents and shall be binding upon the heirs, executors, administrators, successors and assigns of the Successful Respondent.

### **Acknowledgement**

I \_\_\_\_\_, confirm that I have read, understand and agree to the requirements outlined in Appendix H – Agreement Acknowledgement.

\_\_\_\_\_  
Signature

\_\_\_\_\_  
Date

6.9 Appendix I – Sample Photos



## 6.10 Appendix J – Excavator Bucket Dimensions

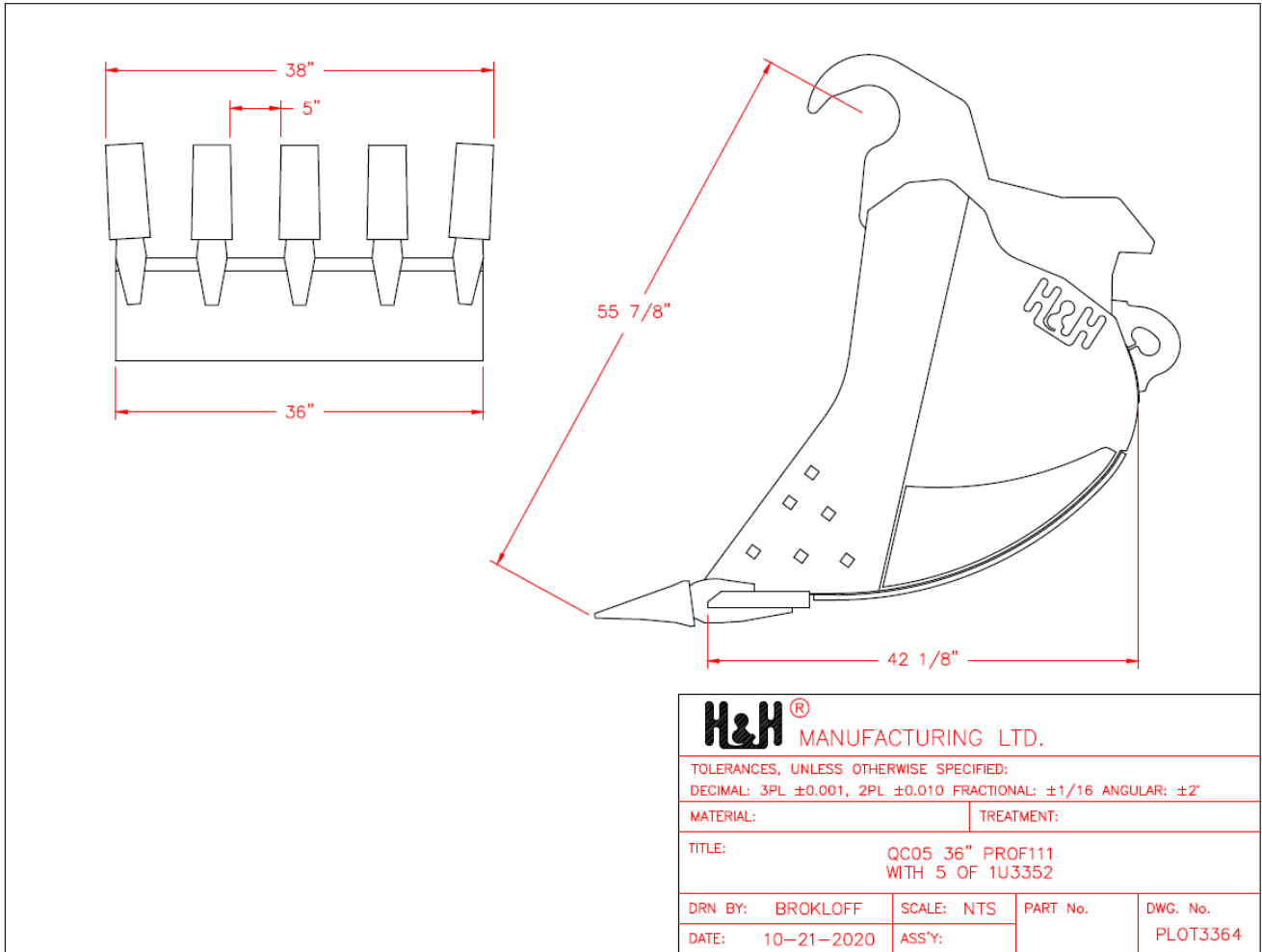

## 6.11 Appendix K – Delivery Notice

**\*\*MANDATORY COMPLETION\*\***

Complete and affix this delivery notice to your Tender submission envelope.

<p style="text-align: center;"><b>RFT No. ENV 23-001</b></p> <p style="text-align: center;"><b>Steel Landfill Cover Plates</b></p> <p style="text-align: center;">Deliver To:</p> <p style="text-align: center;">Township of Minden Hills 7 Milne Street, P.O. Box 359 Minden, ON K0M 2K0</p> <p style="text-align: center;">Attention: Sherry Mulholland</p> <p>Respondent's Company Name: _____</p> <p>Received By: _____ at the Municipal Office, On the _____ day of _____, 20____ at _____ am/pm</p> <p>From: _____ (Name of Person or Organization Delivering Documents)</p> <p><b>Respondent's Contact information for communique from the Township:</b></p> <p>Contact Individual: _____</p> <p>Contact e-mail: _____</p> <p>Contact phone: _____</p> <p style="text-align: center;"><b>THIS DELIVERY NOTICE IS TO BE AFFIXED TO THE OUTSIDE OF THE SEALED SUBMISSION</b></p>
---